



+ + + +  
 + + + +  
 + + + +  
 + + + +

# FIXINGS



OH - Standard fixing with oval holes



R - Round holes fixing



T - Tooth fixing

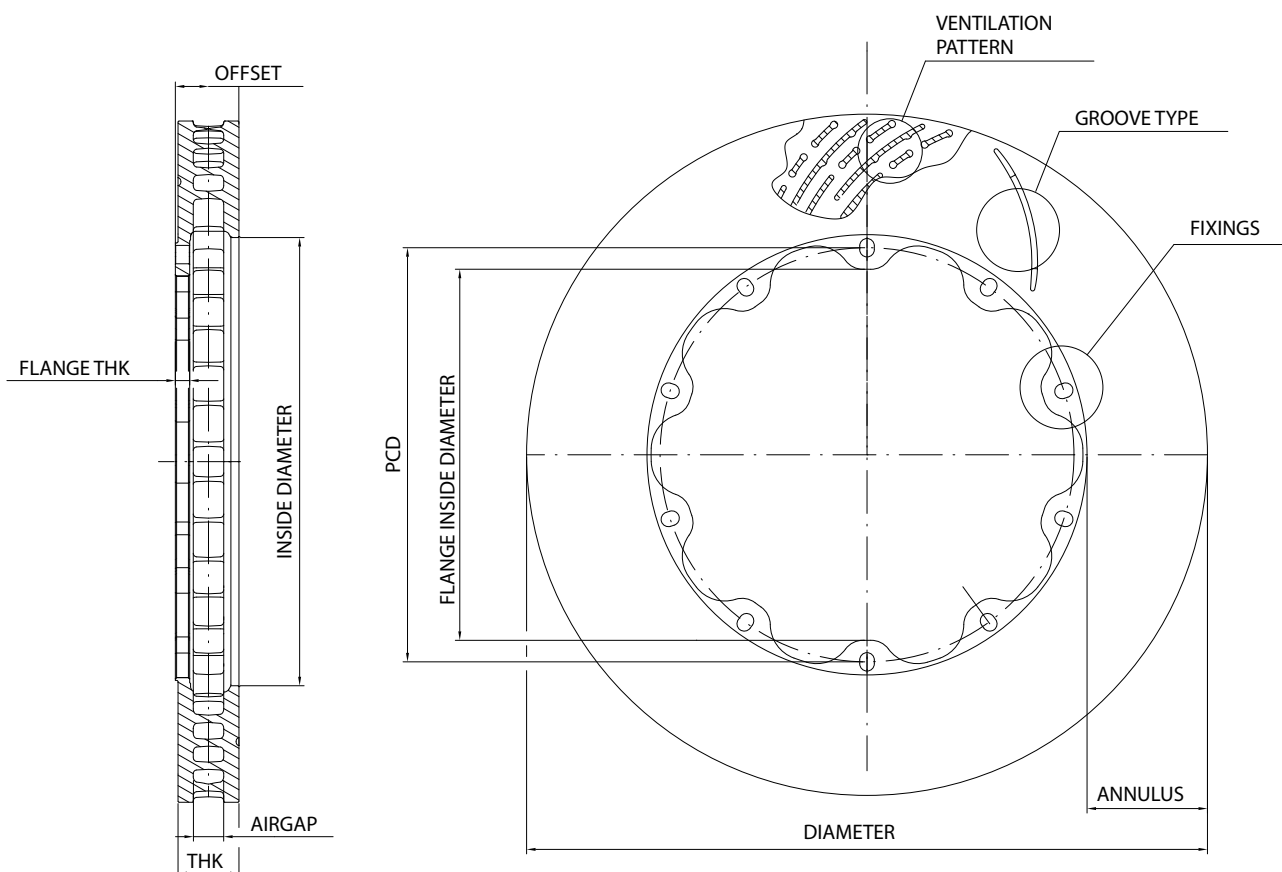

+ + + +  
 + + + +  
 + + + +  
 + + + +

# GROOVE TYPE

+++  
+++  
+++  
+++



P - plain disc



T1 - groove type 1



T3 - groove type 3



T5 - groove type 5



T5L - groove type 5 with logo

T2 - groove type 2: image not available.

T3L - groove type 3 with logo: image not available.

2

## GROOVE EFFECTS

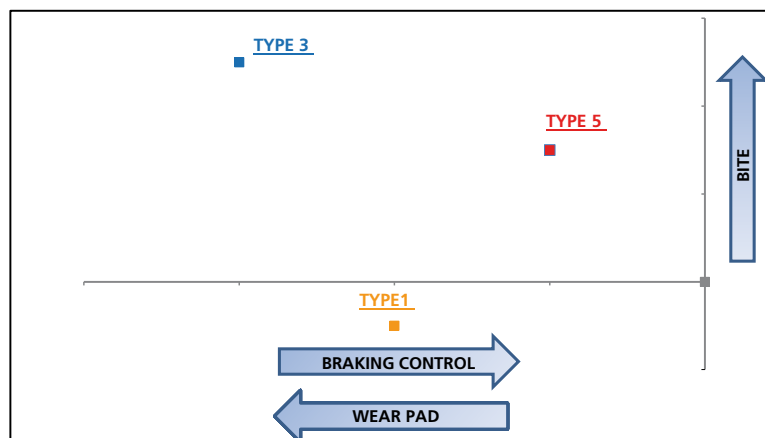

+++  
+++  
+++  
+++



+ + + +  
 + + + +  
 + + + +  
 + + + +

P/N	Diameter (mm)	Th (mm)	Annulus (mm)	Airgap (mm)	Weight (Kg)	Ventilation (pillar/ vanes)
08.4695.41	278	6,4	46	0	1,8	SOLID
08.4695.43	278	6,4	45,5	0	1,8	SOLID
X95.50.60	278	6,4	45,5	0	1,7	SOLID
09.8386.15	278	16	45,25	6,5	2,7	P
09.8386.16	278	16	40,25	6,5	2,45	P
09.A261.11/21	278	18	39	8,5	2,5	V
09.A261.13/23	278	18	39	8,5	1,95	V
09.A261.30/40	278	18	39	8,5	2,2	V
09.A261.50/60	278	18	39	8,5	2,54	V
09.9021.31/41	280	28	45	16	4	60V
09.5890.10/20	280	25,4	44,75	14	3,3	V
09.5890.30/40	280	25,4	45	14	NA	V
09.5890.31/41	280	28	45	14	3,9	V
09.7277.75/85	295	25,4	45,5	16,75	3,9	V
09.7277.10/20	295	28	52,5	13,75	NA	V
09.7277.16/26	295	28	45,5	13,75	NA	V
09.9021.30/40	295	32	52,5	16	6,2	60V
01.7143.10	300	22	47,5	7,5	6,8	P
09.7277.13/23	300	25,4	52,5	13,75	NA	V
09.8647.70/80	300	28	52,5	16	5	V
09.9021.18/28	300	28	52,5	16	5	60V
XA3.33.10/11	304	32	56,1	16	6,4	V
09.7277.36/46	313	25,4	44,5	13,75	4,3	V
09.9221.55/65	313	25,4	44,5	16	NA	60V
09.9222.71/81	313	32	44	19,8	4,5	V
01.7813.10	316	20	49	7	7,9	P
19.7813.20	316	20	49	7	7,9	P
09.5682.50/60	320	28	52,5	16,5	5,2	V
09.8356.30/40	320	28	52	16,5	5,17	V
01.7142.10	320	32	63,5	13,5	9,7	P
09.9226.12/22	324	28	54	16,5	6,1	V
09.A882.10/20	326	26	44,5	16,5	4	V
01.7812.10	326	30	63,5	12	10,2	P
19.7812.20	326	30	63,5	12	10,2	P
09.5682.56/66	328	27	47,5	16,5	4,9	V
01.5682.72/82	328	28	54	16,5	6,9	V
09.8357.11/21	328	28	63,5	16,5	6,1	V
09.9226.10/20	328	28	54	16,5	NA	V
XA3.41.18/28	328	28	54	16,5	5,65	72V
09.8358.70/80	328	30	53,5	16,5	6,3	72V
09.5682.53/63	328	32	54	16,5	6,6	V
09.9226.39/49	328	32	54	16,5	6,4	V
09.9227.12/22	328	32	64	16,5	NA	V
09.9227.10/20	328	35	64	16,5	NA	V
09.9229.10/20	328	35	64	19	8,3	72V

+ + + +  
 + + + +  
 + + + +  
 + + + +

Offset (mm)	Fixing type	PCD (mm)	Inside diameter (mm)	Flange inside diameter (mm)	Flange Th (mm)	GROOVE TYPE	DRILL
3,2	round holes 8,5	164	186	146	6,4	0	50
3,2	OH 8x10	172,5	187	154	5	0	0
2,5	OH 8x10	172,5	187	154	5	0	60
8,5	round holes 8,5	176	187,5	156	4,5	T1 x 4	0
8,5	round holes 8,5	186	197,5	166	4,5	T1 x 4	0
9	T	NA	200	171	4,5	T5 x 4	0
9	T	NA	200	171	4,5	T5 x 4	0
9	T	NA	200	171	4,5	T5 x 4	0
8,5	OH 8x10	186	200	166	4,5	T5 x 4	0
28,7	OH 9,5x15	176,8	190	151	5	T5 X 8	0
13	OH 8x10	176	190,5	155	6	0	80
12,7	OH 9,5x15	176,8	190	151	5	T1 x 4	0
12,7	OH 9,5x15	176,8	190	151	5	T1 x 4	0
9,8	T	NA	204	175	6	T5L	0
12,7	OH 8x10	176	190	154	6	T1 x 8	0
12,7	OH 8x10	190	204	166	6	T1 x 8	0
15	OH 8x10	176	190	154	8	T3	0
52,2	monolithic disc	114,3	NA	NA	NA	0	0
12,7	OH 8x10	181	195	160	6	T1 x 8	0
14	T	NA	195	146	6	T5L	0
12,7	OH 8x10	181	195	160	6	T2	0
29,3	SLOTS 12,6 x 12	176,8	191,8	161,2	4,75	0	96
13,9	OH 8x10	210	224	187	6	T1 x 8	0
25,1	round holes 8,5	210	224	194	4,5	T5 X 8	0
16,5	OH 8x10	210	225	190	6	T5 x 10	0
59	monolithic disc	100	NA	NA	NA	0	0
59	monolithic disc	114,3	NA	NA	NA	0	0
15,5	OH 8x10	200	215	182	6	T1 x 8	0
29	OH 8x10	200	216	182	6	T5 x 10	0
37	monolithic disc	114,3	NA	NA	NA	0	0
15	OH 8x10	206	216	182	6	T5 x 10	0
27,5	OH 8x10	225	237	202	6	T5 x 10	0
46	monolithic disc	100	NA	NA	NA	0	0
46	monolithic disc	114,3	NA	NA	NA	0	0
15	OH 8x10	218	233	196	6	T1 x 8	0
15	OH 8x10	206	220	184	6	0	0
29	OH 8x10	184	201	161	6	T5 x 6	0
15	OH 8x10	206	220	184	6	T5 x 10	0
29	OH 8x10	206	220	184	6	T2	0
30	OH 8x10	206	221	184	6	T2	0
17	OH 8x10	206	220	184	8	T2	0
17	OH 8x10	206	220	184	8	T5 x 10	0
17,5	OH 8x10	184	200	161	8	T5 x 12	0
17,5	OH 8x10	184	200	161	8	T5 x 12	0
17,5	OH 8x10	184	200	161	8	T5 x 12	0

+++  
+++  
+++  
+++

2

+++  
+++  
+++  
+++

+ + + +  
 + + + +  
 + + + +  
 + + + +

P/N	Diameter (mm)	Th (mm)	Annulus (mm)	Airgap (mm)	Weight (Kg)	Ventilation (pillar/ vanes)
09.8667.50/60	330	28	63	16,5	7,5	V
09.9306.50/60	330	32	52	17	8,4	72V
09.9306.70/80	330	32	52,5	17	6,7	72V
09.9306.71/81	330	32	52,5	17	6,74	72V
09.8666.53/63	332	32	53,5	16,5	6,9	V
09.8666.70/80	332	32	53,5	16,5	6,8	V
09.A465.70/80	332	32	53,5	17	6,6	72V
09.5759.36/46	345	28	47,5	17	NA	V
09.9306.12/22	350	28	63	17	6,6	72V
09.9306.10/20	350	34	68	17	9,3	72V
09.5759.17/27	355	28	53,5	17	5,5	V
09.A996.10/20	355	30	53	17	6,2	V
01.5759.16/26	355	32	53,5	17	6,9	V
09.5683.19/29	355	32	53,5	19,75	6,3	V
09.9306.11/21	355	32	53,5	17	NA	72V
09.9404.12/22	355	32	60,5	17	8,14	72V
09.A026.13/23	355	32	53,5	17	7,5	V
09.A027.13/23	355	32	53,5	20	6,54	V
09.A465.11/21	355	32	53,5	17	7,23	72V
09.A996.11/21	355	32	53	17	7,3	V
XA2.91.34/35	355	32	53,5	20	NA	V
09.9306.14/24	355	35	53,5	17	8,6	72V
09.A464.10/20	365	32	63,5	17	8,3	72V
09.8528.58/68	370	32	52	17	7,8	72V
09.A009.10/20	370	32	52,5	20	7,16	72V
09.8528.55/65	370	35	55	17	9	72V
09.8528.51/61	375	35	57,5	17	9,2	72V
09.8363.21/31	380	30	57,5	17	7,4	V
09.8528.74/84	380	32	52,5	17	9,3	72V
09.A009.74/84	380	32	52,5	20	7,37	72V
09.A464.54/64	380	32	52,5	17	7,8	72V
09.A464.74/84	380	32	52,5	17	7,8	72V
XA2.91.32/33	380	32	64,25	20	NA	V
09.8528.12/22	380	34	65	17	10,2	72V
09.A009.12/22	380	34	65	20	8,47	72V
09.8528.78/88	380	35	52,5	17	9,3	72V
09.A464.58/68	380	35	52,5	17	8,9	72V

+ + + +  
 + + + +  
 + + + +  
 + + + +

Offset (mm)	Fixing type	PCD (mm)	Inside diameter (mm)	Flange inside diameter (mm)	Flange Th (mm)	GROOVE TYPE	DRILL
17	OH 8x10	188	204	166	8	T3	0
34,5	OH 8x10	210	226	190	8	T2	0
18,5	OH 8x10	210	225	190	8	T3	0
18,5	OH 8x10	210	225	190	8	0	0
18,5	OH 8x10	210	225	190	8	0	0
18,5	OH 8x10	210	225	190	8	T3 x 36	0
33	T	NA	225	196	7	T5 x 10	0
15,5	OH 8x10	233	250	209	6	T1 x 8	0
15,5	OH 8x10	206	224	182	6	T3	0
17,9	OH 8x10	197	214	174	8	T3	0
15,5	OH 8x10	233	248	209	6	T1 x 8	0
30	T	NA	249	219	6	T5L	0
18,5	OH 8x10	233	248	209	8	0	0
16	T	NA	248	219	6	T5L	0
18,5	OH 8x10	233	248	209	8	T3	0
18,5	OH 8x10	219	234	196	8	T5 x 10	0
18,5	OH 8x10	233	248	209	8	T5 x 10	0
18,5	OH 8x10	233	248	209	8	T5 x 10	0
33	T	NA	248	219	7	T3	0
31	T	NA	249	219	6	T5L	0
34,5	OH 8x10	233	248	209	8	T3	0
18,5	OH 8x10	233	248	209	8	T3	0
33	T	NA	238	209	7	T3	0
34,5	OH 8x10	245	266	221	8	T2	0
18,5	OH 8x10	245	265	221	8	T2	0
18,5	OH 8x10	245	260	221	8	T1 x 8	0
18,5	OH 8x10	245	260	221	8	T3	0
18	OH 8x10	245	265	221	8	T3L	0
34,5	OH 8x10	258	275	234,5	8	T3	0
34,5	OH 8x10	258	275	234,5	8	T5 x 10	0
33	T	NA	275	246	7	T3	0
33	T	NA	275	246	7	T5 x 10	0
34,55	OH 8x10	232	251,5	207	8	T3	0
18,5	OH 8x10	231	250	207	8	T3L	0
18,5	OH 8x10	231	250	207	8	T3	0
18,5	OH 8x10	258	275	234,5	8	T3	0
34,5	T	NA	275	246	7	T3	0

++  
++  
++  
++

2

++  
++  
++  
++

# OVAL HOLES

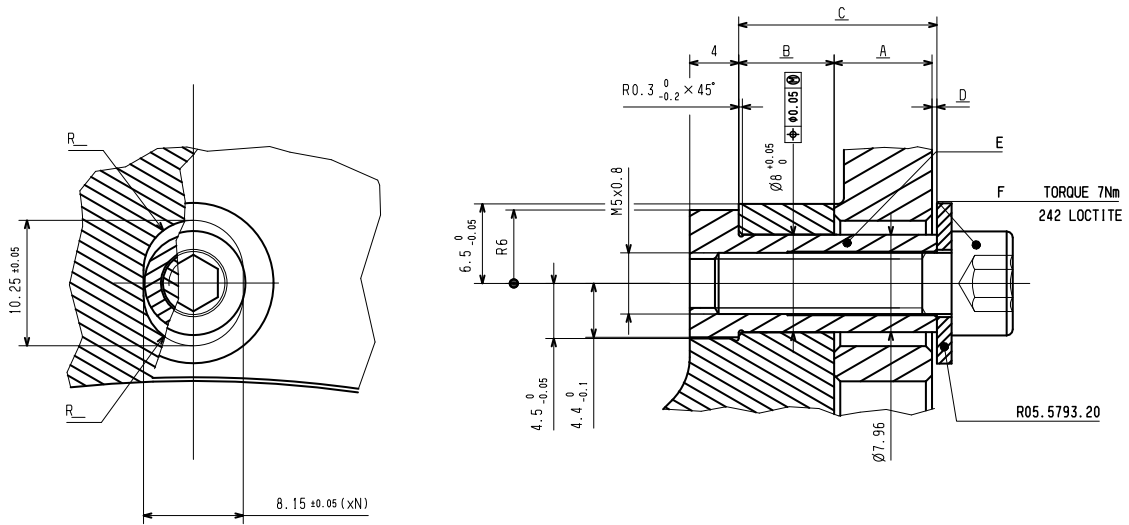

A	B	C	D	E	F
4.55 4.45	5.85 5.75	10.70 10.65	0.50 0.25	X 8.020.09	A1.68.3J.103
5.05 4.95	5.55 5.45	10.70 10.65	0.30 0.05	X 8.020.09	A1.14.44.103
6.05 5.95	5.85 5.75	12.20 12.15	0.50 0.25	X 8.020.08	A1.68.3J.103
6.05 5.95	9.85 9.75	16.20 16.15	0.50 0.25	X 2.030.26	A1.68.3J.105
8.05 7.95	7.85 7.75	16.20 16.15	0.50 0.25	X 2.030.26	A1.68.3J.105

XA19902 esp A

# ROUND HOLES

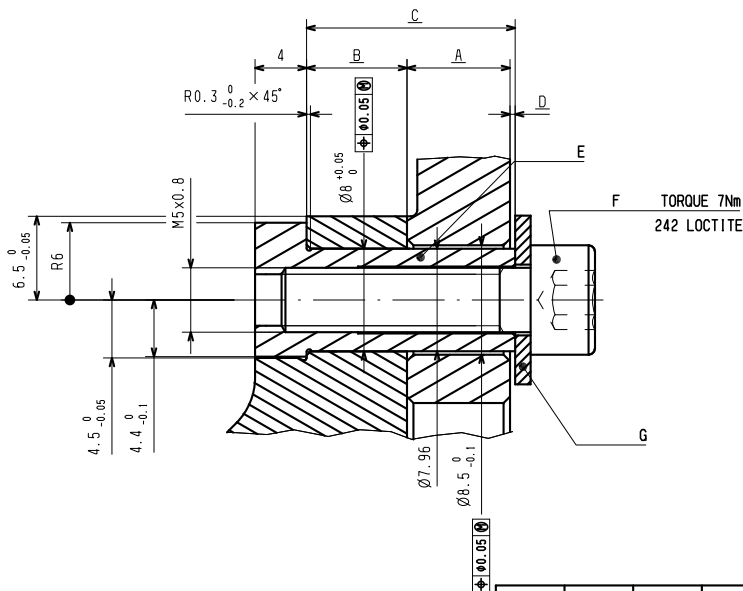

A	B	C	D	E	F	G
3.1 2.9	7.6 7.5	10.70 10.65	0.40 0.05	X 8.020.09	A1.68.3J.103	R05.5793.20
4.55 4.45	6.05 5.95	10.70 10.65	0.30 0.05	X 8.020.09	A1.68.3J.103	X 9.002.47
6.05 5.95	6.05 5.95	12.20 12.15	0.30 0.05	X 8.020.08	A1.68.3J.103	X 9.002.47
8.05 7.95	8.05 7.95	16.20 16.15	0.30 0.05	X 2.030.26	A1.68.3J.105	X 9.002.47

XA1.99.03 esp A





+++  
+++  
+++  
+++

# HEAVY DUTY

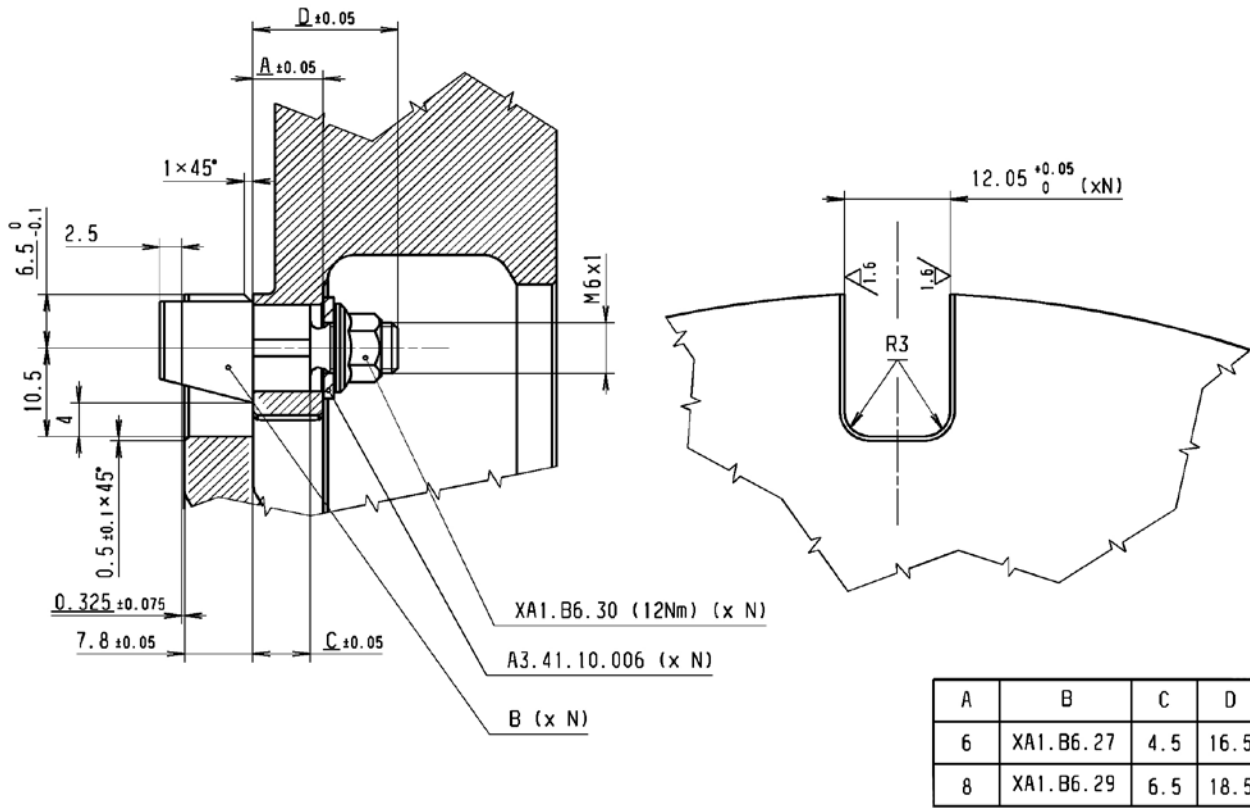

# CARBON DISC

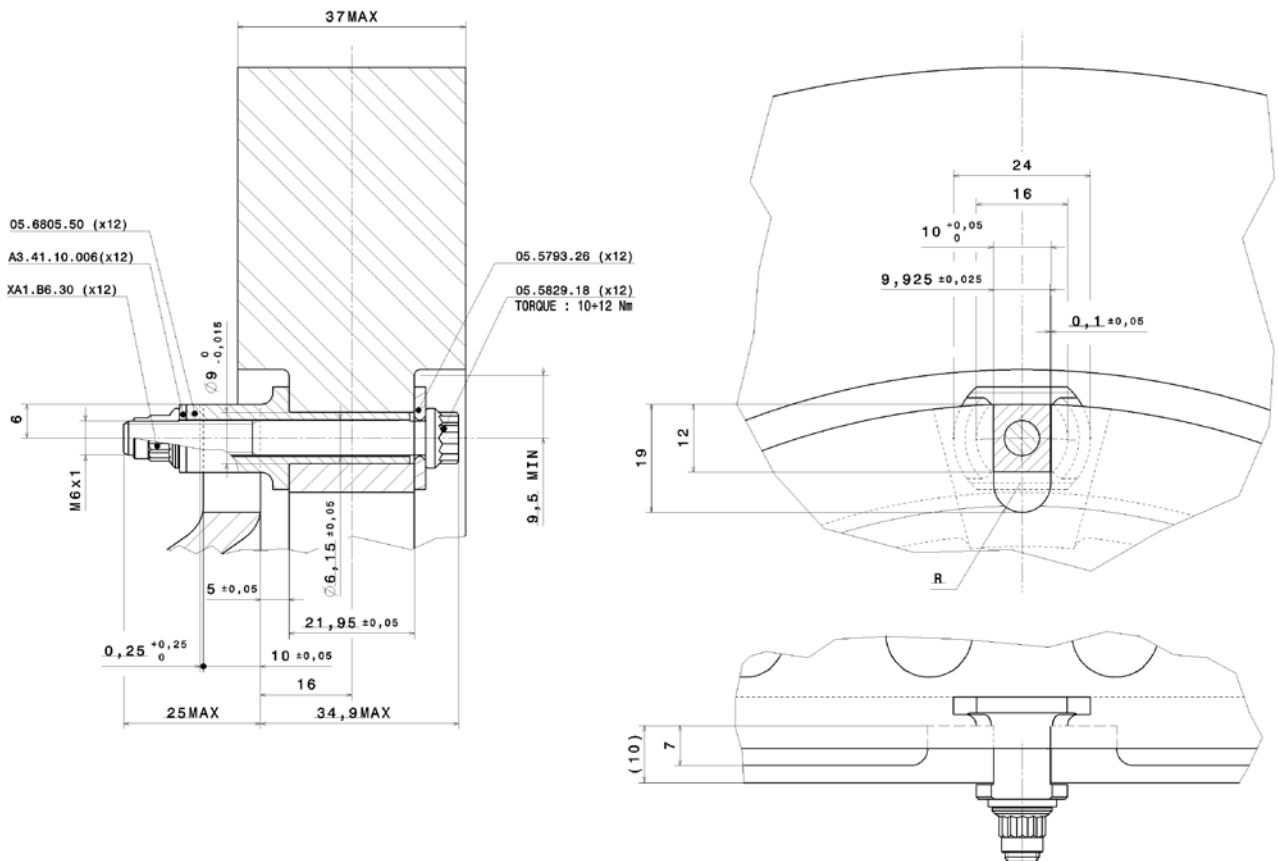

+++  
+++  
+++  
+++

+ + + +  
 + + + +  
 + + + +  
 + + + +

## CARBON DISCS

P/N	Material	Diameter (mm)	Th (mm)	Annulus (mm)	Ventilation holes (mm)	Weight (Kg)
09.7843.21	CCR 300	355	37	53	15	2,4
09.7843.11	CCR 300	380	37	53	15	3,15
XA2.D9.61	CER 100	355	32	53	12	NA
XA2.D9.69	CER 100	355	35	53	12	NA
XA2.D9.73	CER 100	380	32	53	12	2,9
XA2.D9.79	CER 100	380	35	53	12	NA
XA6.M3.C3	CER 200	355	32	53	12	NA
XA6.M3.D3	CER 200	355	35	53	12	NA
XA6.M3.C2	CER 200	380	32	53	12	2,9
XA6.M3.D2	CER 200	380	35	53	12	NA

2

## CARBON PADS

P/N	Material	Th (mm)	Annulus (mm)	Weight (Kg)
07.9076.10	CCR 400	25	53	0,32
07.9076.50	CCR 400	26	53	0,33
07.9076.20	CCR 400	31,5	53	0,43
07.9076.30	CCR 500	31,5	53	0,435

+ + + +  
 + + + +  
 + + + +  
 + + + +